

Application Note

Mounted Resonance Measurements using Type 2525

by N. Johan Wismer & Hans Konstantin-Hansen, Brüel & Kjær, Denmark

With Measuring Amplifier Type 2525, Brüel & Kjær has not introduced just a simple amplifier, but a sophisticated measurement system. Besides its ability to amplify signals and to display the signal's RMS and peak values, the Type 2525 has a number of other facilities. In this application note, we are going to focus on its capability to perform mounted resonance tests of piezoelectric accelerometers. With this feature the Type 2525 is able to measure the resonance frequency of the accelerometer, and by comparing the measured frequency with the one specified on the calibration chart, it is possible to determine whether the accelerometer is correctly mounted or not.

Introduction

Measuring Amplifier Type 2525 has a large number of features that make it suitable for a wide number of different applications, such as product and prototype testing. The Type 2525 can also advantageously replace many older amplifiers in a number of situations. Among the new and exciting features of the Type 2525, we will restrain ourselves to mentioning the following ones:

- **Charge and CCLD inputs.** With this combination, you can use both charge devices with their exceptional dynamic range, or the new popular CCLD (Constant Current Line Drive) devices, including DeltaTron® accelerometers, and CCLD compatible microphone preamplifier Type 2671. When using charge devices, you can select between either grounded or floating mode.

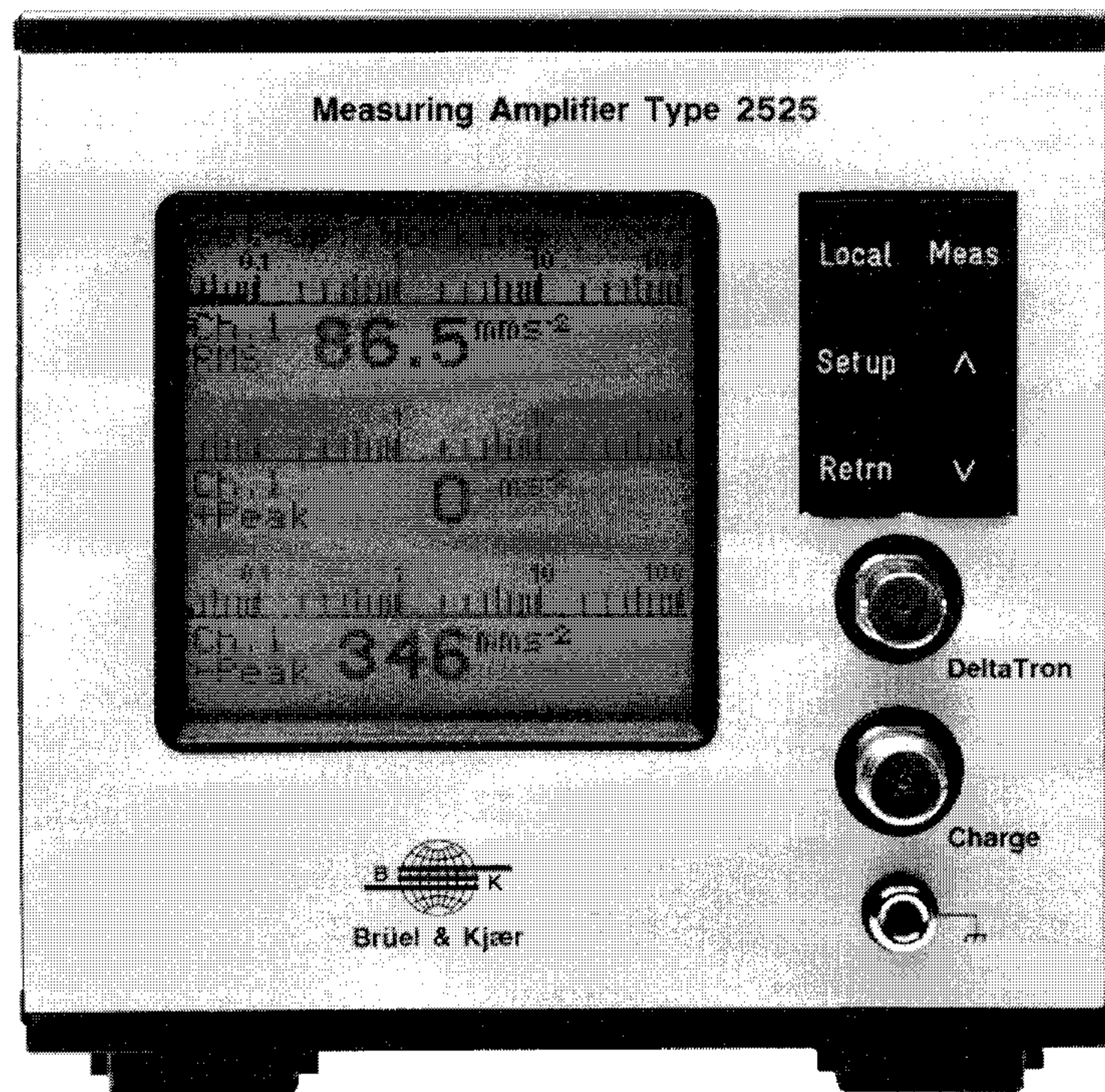

- **Built-in detector.** Not only can the amplifier calculate the RMS and peak (peak-peak, positive or negative peak) values of the measured signal, but the values can be displayed on the built-in screen, they can be read via the instrument interface, and finally one selectable detector value is available as a voltage output on the back of the Type 2525.
- **Built-in filters, possibility of using user-defined filters.** The 4 low-pass filters have cut-off frequencies at 1k, 3k, 10k, 30kHz, and a roll-off of 40dB/decade. The 6 high-pass filters have cut-off frequencies at 0.1, 0.3, 1, 3, 10, 30Hz, and roll off at 60dB/decade. The optional user-defined filters can be of two types: either implemented on a printed circuit board that can be plugged in inside the instrument, or an external filter connected to the Type 2525 via connectors on the back of the amplifier.
- **Autorange.** This feature enables the instrument to make full use of the dynamic range of the detectors, and all other internal circuits.
- **Level monitoring with alarm output.** The amplifier can monitor the RMS or peak levels, and set the alarm if a preset level has been exceeded. The alarm will always be shown on the display, and it can be monitored in two

additional ways, either via the instrument interface (through polling), or via a relay output on the Type 2525.

- **Mounted resonance test (pat. pend.).** This feature is used to check if the accelerometer is correctly mounted or not. This feature will be described in detail in this application note. A large number of different accelerometers can thus be tested for correct mounting, for example Type 4370, 4378, 4382, 4383, 4284, 4391.
- **IEEE-488 and serial interface.** This enables a computer to control and get information from the measuring amplifier. All the instrument's features can be remotely controlled, as for example input type, amplifier gain, and filter settings. Among the parameters that can be read are vibration levels (detector values), amplifier gain as determined by the autorange feature, overload and alarm level information, and the result of the mounted resonance test.

Mounted Resonance Test

Measuring Amplifier Type 2525 performs the mounted resonance test in a relatively simple way. A short voltage pulse (see Fig.1) is sent to the accelerometer. This pulse is converted to a mechanical pulse by the piezoelectric element(s) and causes the accelerometer's seismic mass to vibrate. The Type 2525 then switches over to a measurement mode, and the time it takes N sine periods to be detected is measured.

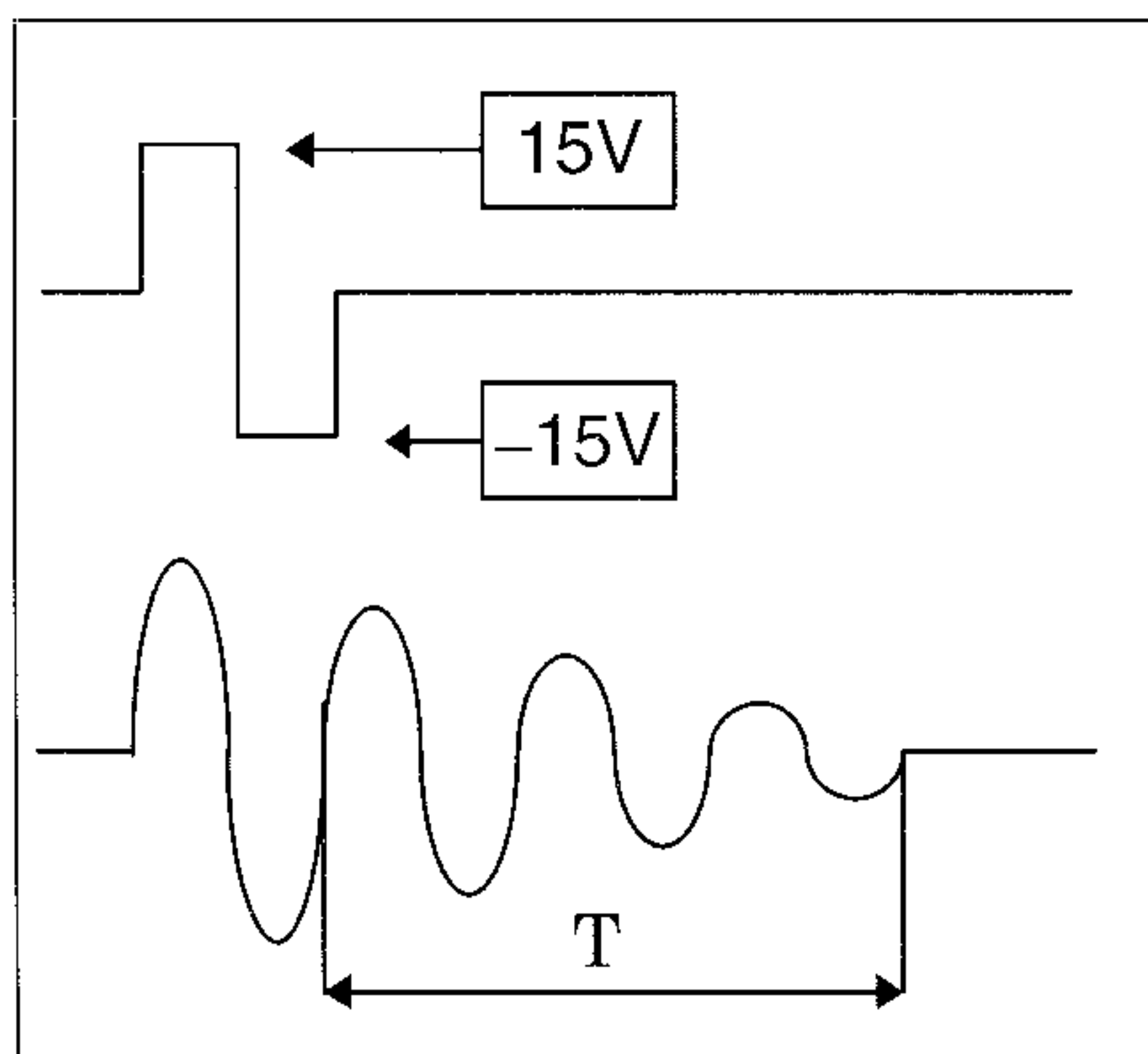

Fig. 1 The pulse sent to the accelerometer, and the measured response

The measured resonance frequency is then displayed:

$$f_{measured} = N/T \quad (1)$$

The Theory

A piezoelectric accelerometer mounted on an infinitely heavy (and stiff) base, can be viewed as a simple single degree of freedom (SDOF) system consisting of one mass connected to the base by an elastic element (Fig.2).

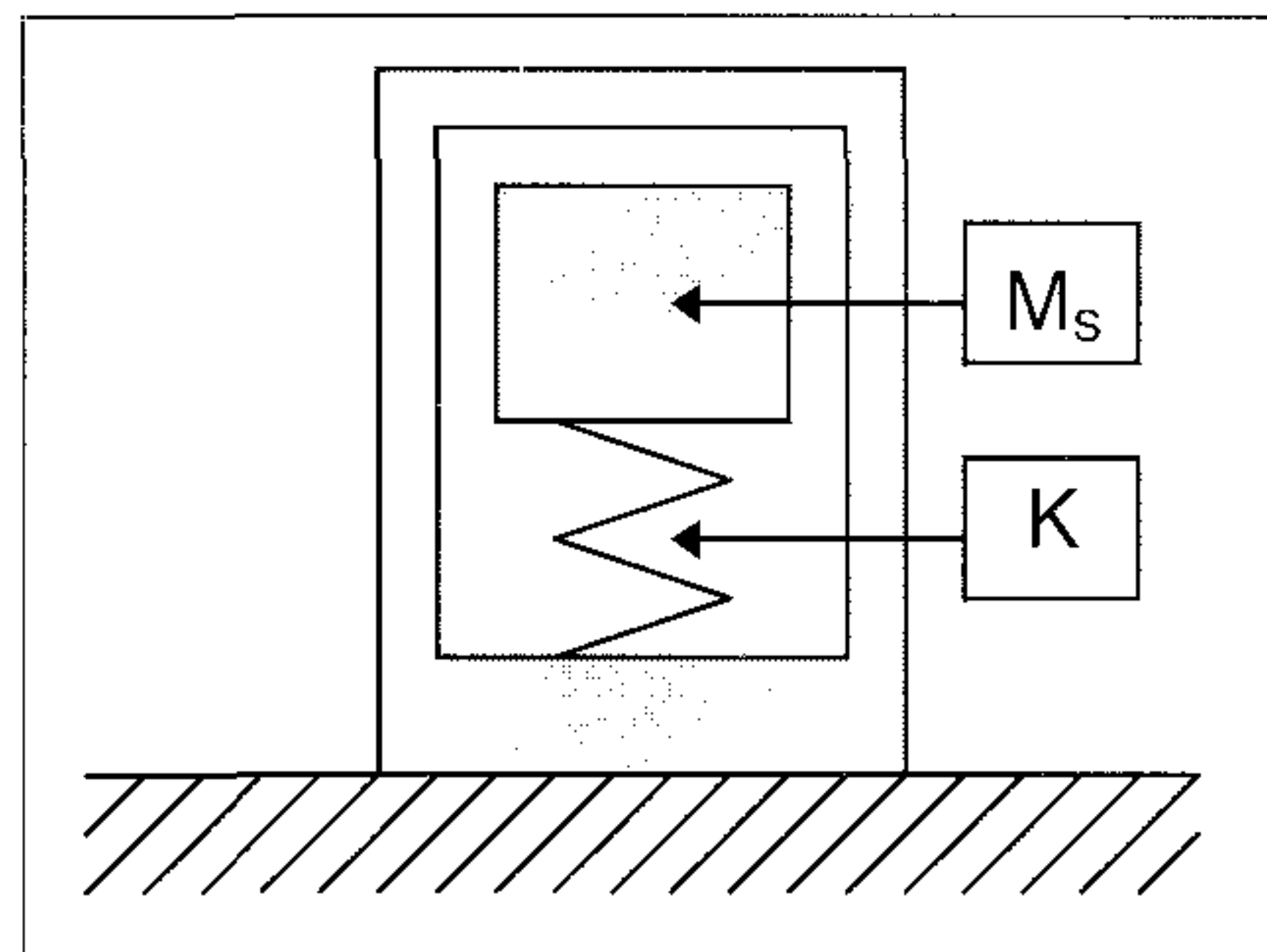

Fig. 2 Model of an accelerometer mounted on a heavy, stiff base

M_s is the seismic mass, and K is the equivalent stiffness of the piezoelectric elements. The piezoelectric elements work both as springs and as charge generating devices. The resonance frequency of this system can be shown to be:

$$\omega_m = 2 \times \pi \times f_m = \sqrt{K/M_s} \quad (2)$$

where ω_m is the mounted resonance frequency in rad/s, and f_m is the mounted resonance frequency in Hertz.

If the accelerometer is free (not mounted on anything), then the model looks slightly different. The model is now a two mass system connected by an elastic element (Fig.3).

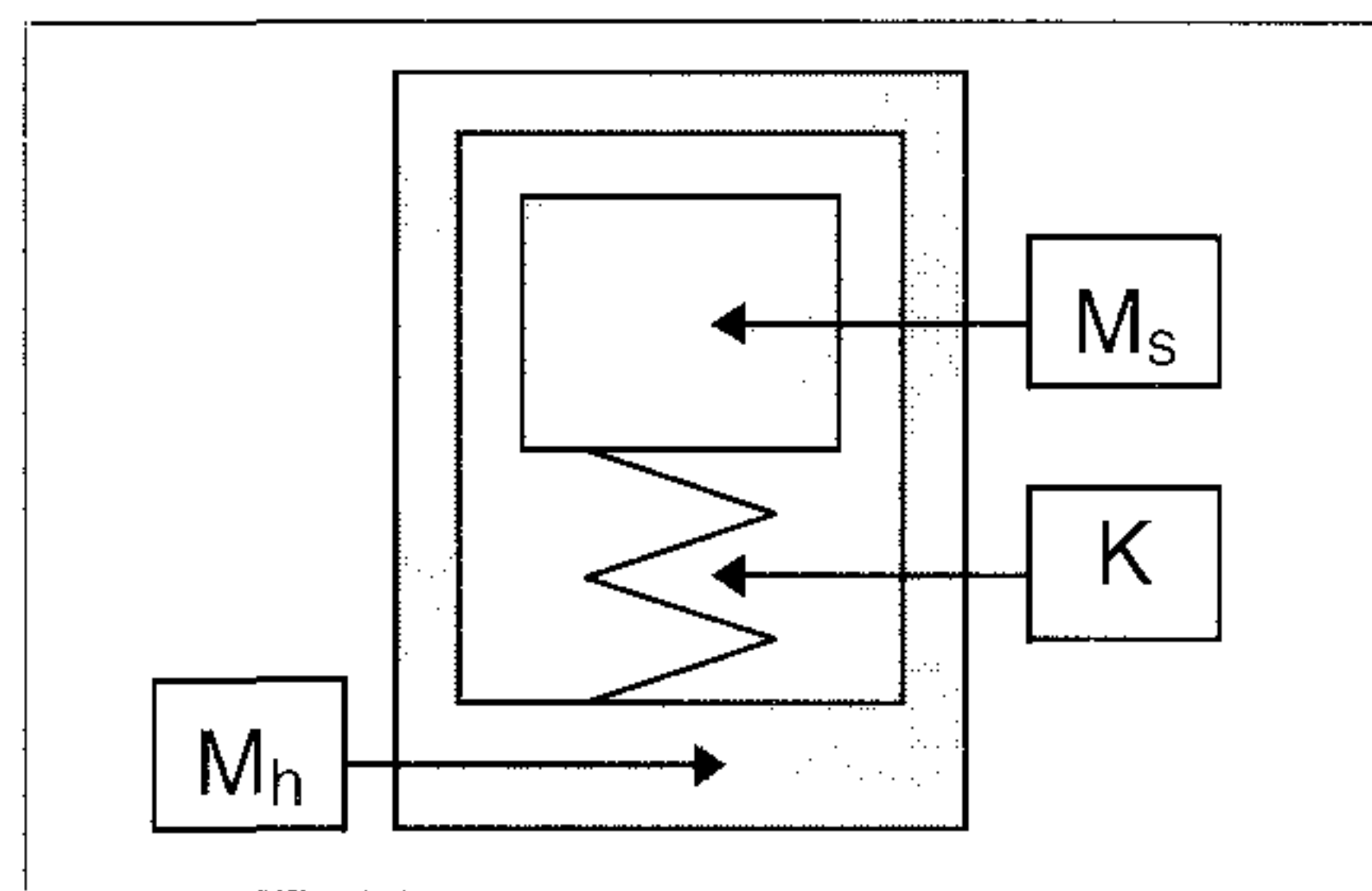

Fig. 3 Model of an unmounted (free) accelerometer

M_h is the mass of the accelerometer housing.

For this system the resonance frequency can be shown to be:

$$\omega_f = 2 \times \pi \times f_f = \sqrt{K/\mu} \quad (3)$$

where μ is the reduced mass defined as:

$$\mu = \frac{M_s \times M_h}{M_s + M_h} \quad (4)$$

Now if we look at a specific accelerometer, for example Type 4382, we can read the following data from the product data and calibration sheet:

- Accelerometer mass: 17g
- Seismic mass: 6.6g
- Mounted resonance freq.: 28kHz

Combining these two last pieces of information with equation (2), yields a stiffness K of approximately 200MN/m ($= 200 \times 10^6$ N/m).

The mass of the accelerometer housing is equal to the accelerometer mass minus the seismic mass:

- $M_h = 10.4$ g

The reduced mass μ can then be found using equation (4):

- $\mu = 4.0$ g

The resonance frequency of the accelerometer when it is free (not mounted), can now be found using equation (3):

- $f_f = 35$ kHz

The two situations described above are the extremes of the ways an accelerometer can be mounted. Either mounted on an infinitely heavy and stiff base, or not mounted at all.

Usually we will be dealing with some situation in between these two extremes. These "in between" situations are much more complicated to deal with, as they have to take more factors into account, for example:

- The thickness and other geometrical properties of the object the accelerometer is mounted on
- The material the accelerometer is mounted on (steel, aluminum, brass, etc.)
- The way the accelerometer is mounted (screwed on, glued, beeswax, etc.)

Due to this large amount of factors, a theoretical investigation is beyond the scope of this application note. We will therefore restrain ourselves to an experimental investiga-

tion of the subject. The only thing we will mention here is that the resonance frequency can both decrease or increase depending on the external factors listed above.

Measurements

When the Type 2525 is switched on, the main set-up can be displayed:

```

Main set-up
  Measurement set-up
  Display set-up
  Lin./dB read-out
  100 pC 159 Hz Ref.
  Interface set-up
  Reset det./channel
  SI/Imperial units
  Decimal point
> Mounted resonance
  Display mode
  Set-up memory
  Back-lighting
  
```

Fig. 4 Main set-up of Type 2525

To perform the mounted resonance test, move the > cursor to the "Mounted resonance" line, and press <Setup>. The Type 2525 will then display the mounted resonance display:

```

Mounted resonance
Channel: 1
  Select imp. freq.
> Measure resonance

Impulse frequency:
  28.00 kHz
Mounted resonance:
  26.87 kHz

Charge input only!

If unstable reading:
Probably bad mounting
  
```

Fig. 5 Mounted resonance display

Prior to the measurement you must set the nominal mounted resonance frequency. In this case for Accelerometer Type 4382, the nominal mounted resonance is 28kHz. The Type 2525 will use this frequency value to generate a pulse with its main frequency content at the specified frequency.

Note that the Type 2525 can only perform the mounting resonance test on charge accelerometers, not on CCLD type accelerometers. This is due to the fact that CCLD devices

have a built-in amplifier, which will prevent the electrical excitation pulse from reaching the piezoelectric elements.

To perform the measurement, move the > cursor to the "Measure resonance" line, and press <Setup>. You will hear some relays click, and after about 3 seconds, the result will be displayed (see Fig.5).

The mounted resonance frequency of a Type 4382 was measured with the accelerometer mounted on a very large block of steel. The resonance frequency of the accelerometer was also measured with the accelerometer hanging freely in the air (Table 1).

Mounted:	26.87kHz
Unmounted:	31.8 ± 2.9kHz

Table 1 Mounted and unmounted resonance frequency as measured by the Type 2525

For the freely hanging accelerometer, the resonance frequency was very unstable. The average value recorded was 31.8kHz, and the standard deviation was 2.9kHz. This is somewhat lower than the values found and calculated in the previous section, but this could be due to the fact that the housing does not behave as a lumped mass.

The measurements were performed on a large number of Type 4382 accelerometers, and the mounted resonance frequencies only varied very little from one accelerometer to the next.

Mounting Errors

First the mounted resonance frequency was measured as a function of the torque used to tighten the accelerometer. The nominal mounting torque for the Type 4382 is 1.8Nm.

Mounting torque [Nm]	Resonance freq. [kHz]
0.4	25.76
0.8	26.87
1.2	26.87
1.6	26.87
2.0	26.87

Table 2 Resonance frequency as a function of mounting torque

From this it can be seen that the resonance frequency is relatively insensitive to the mounting torque, but still: *too low a mounting torque will result in a lowering of the resonance frequency.*

The advantages and disadvantages of the different ways of mounting an accelerometer are described in detail in reference [2], section 4.4.

Another measurement was made with a single strand of copper wire, 0.18mm in diameter, squeezed between the accelerometer and the base material. The resonance frequency was found to be equal to 21.28kHz, as compared to 26.87kHz without the copper wire. If the accelerometer had been mounted on a rough surface, the result would have been affected the same way. *So a bad (soft) mounting will also result in a lower resonance frequency.*

The resonance frequency was also measured as a function of plate thickness. The accelerometer was mounted on square steel plates (100mm×100mm) of different thickness, and the resonance frequencies were measured (Table 3).

Plate thickness [mm]	Resonance freq. [kHz]
1.0	36.96
1.5	34.72
2.0	33.60
3.0	31.36
10.0	29.11

Table 3 Resonance frequency as a function of plate thickness

As opposed to the mounting torque, we can see that the plate thickness affects the resonance frequency greatly. The thinner the plate, the higher the resonance frequency. This also indicates that one has to be careful when mounting the accelerometer on a thin plate. The mere existence of the accelerometer will affect the way the structure vibrates. This effect is termed *mass loading* and is described in detail in reference [2], section 4.3.

Fig.6 shows a theoretically derived relationship between the maximum accelerometer mass and the thickness of a plate for a specified change in the acceleration level (5%) over a defined frequency range.

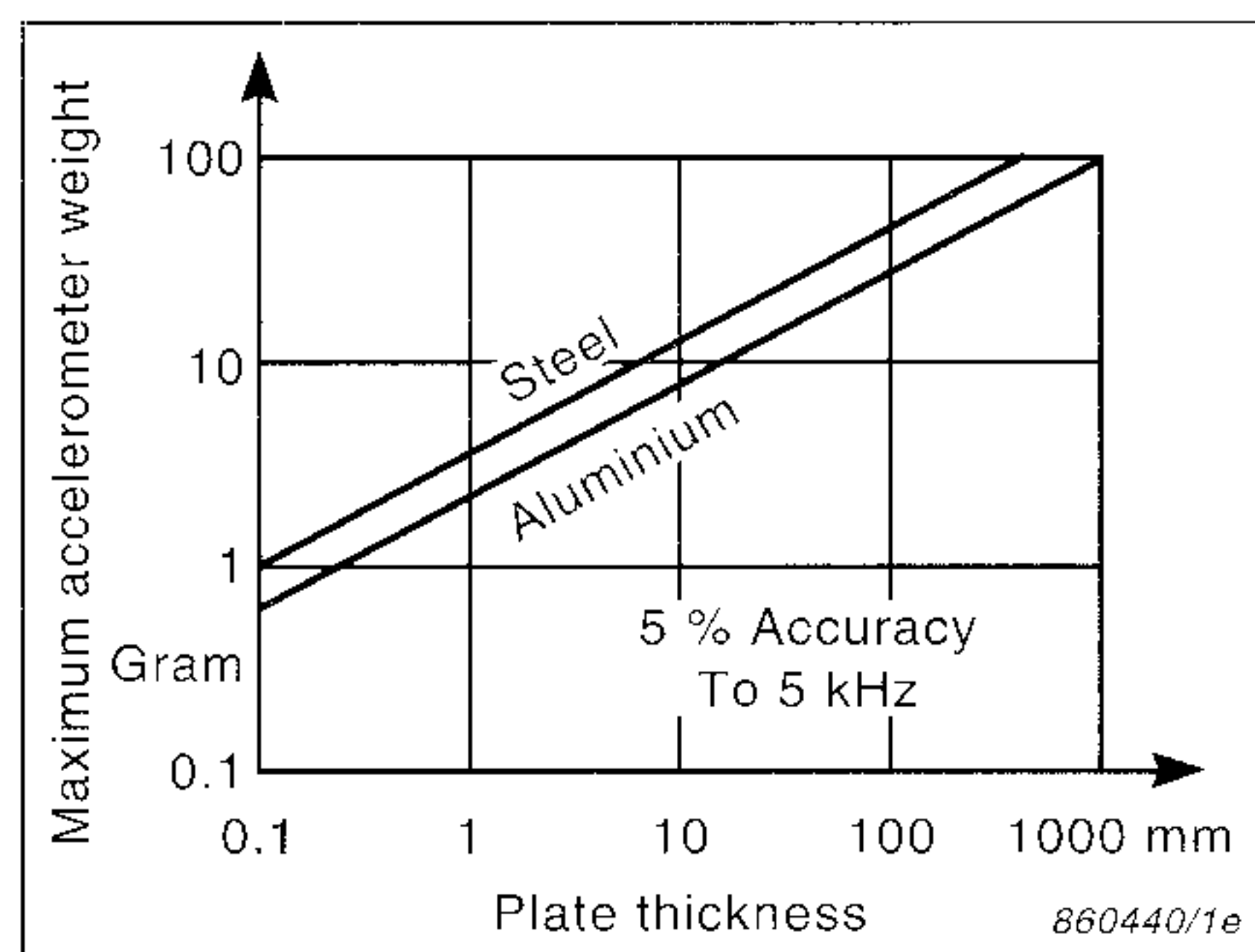

Fig. 6 Theoretically derived relationship for 5% accuracy in measurement on plates

Mounting an accelerometer on too light a structure will result in an increase in the resonance frequency, indicating that there might be a mass loading problem.

Conclusion

The mounted resonance frequency of an accelerometer can be seen to be influenced by a number of factors, such as too low a mounting torque, mounting on too soft a base, or mounting on too light a structure. So any major deviation from the specified mounted resonance frequency should lead to an investigation of the discrepancy.

The mounted resonance test can also be used to check whether there has been any deviation from a previously made reference measurement. For example, if a certain type of motor is being tested, and if the accelerometer is mounted in the same place every time, then the mounted resonance test should always yield the same result.

Also note that a single measurement is usually not enough. As we saw when the unmounted resonance

frequency measurement was made, there was a large variation between consecutive measurements. If a single measurement had been made, we might, by pure chance, have made a measurement indicating that the mounting was good.

On the other hand, a good resonance frequency measurement is no guarantee for a good measurement. There are a large number of other problems that the resonance test does not shield you from. Among these we can mention: base bending problems, high temperatures, high temperature gradients, high sound levels.

A mounted resonance test should therefore only be seen as one measurement quality indicator among many, most of which are based on experience.

References

- [1] Product Data, Measuring Amplifier — Type 2525 (BP 1483)
- [2] Piezoelectric Accelerometers and Vibration Preamplifiers, Theory and Application Handbook, Brüel & Kjær (BB 0694)
- [3] Mechanical Vibration and Shock Measurements, Brüel & Kjær (19-211)

Brüel & Kjær 

WORLD HEADQUARTERS: DK-2850 Nærum · Denmark · Telephone: +45 42 80 05 00 · Telex: 37316 bruka dk · Fax: +45 42 80 14 05

Australia (02) 450-2066 · Austria 00 43-1-816 74 00 · Belgium 016/44 92 25 · Brazil (011) 246-8166 · Canada: East (514) 695-8225 West (604) 591-9300 · China 1-8419 625
 Czech Republic 02-67 021100 · Finland (0)1481577 · France (1) 64 57 20 10 · Germany 06151/8149-0 · Great Britain (081) 954-2366 · Holland 03402-39994
 Hong Kong 548 7486 · Hungary (1) 215 83 05 · Italy (02) 57 60 41 41 · Japan 03-5420-7302 · Republic of Korea (02) 554-0605 · Norway 66 90 44 10 · Poland (0-22) 40 93 92
 Portugal (1) 38 59 256/38 59 280 · Singapore 735 8933 · Slovak Republic 07-49 78 90 · Spain (91) 368 10 00 · Sweden (08) 711 27 30 · Switzerland 01/940 09 09
 Taiwan (02) 713 9303 · Tunisia (01) 750 400 · USA (404) 981-9311
 Local representatives and service organisations worldwide